

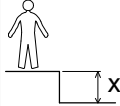

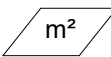

N°		
1	<0.6 m	17 m ²

— Zone d'impact
Impact area
Area de impacto
Fallraum
Valzone



Point de référence
Setting out point
Punto de referencia
Bezugspunkt
Referentiepunt

- - - Espace libre
Free space
Espacio libre
Freiraum
Vrije ruimte

EN1176-1:2017

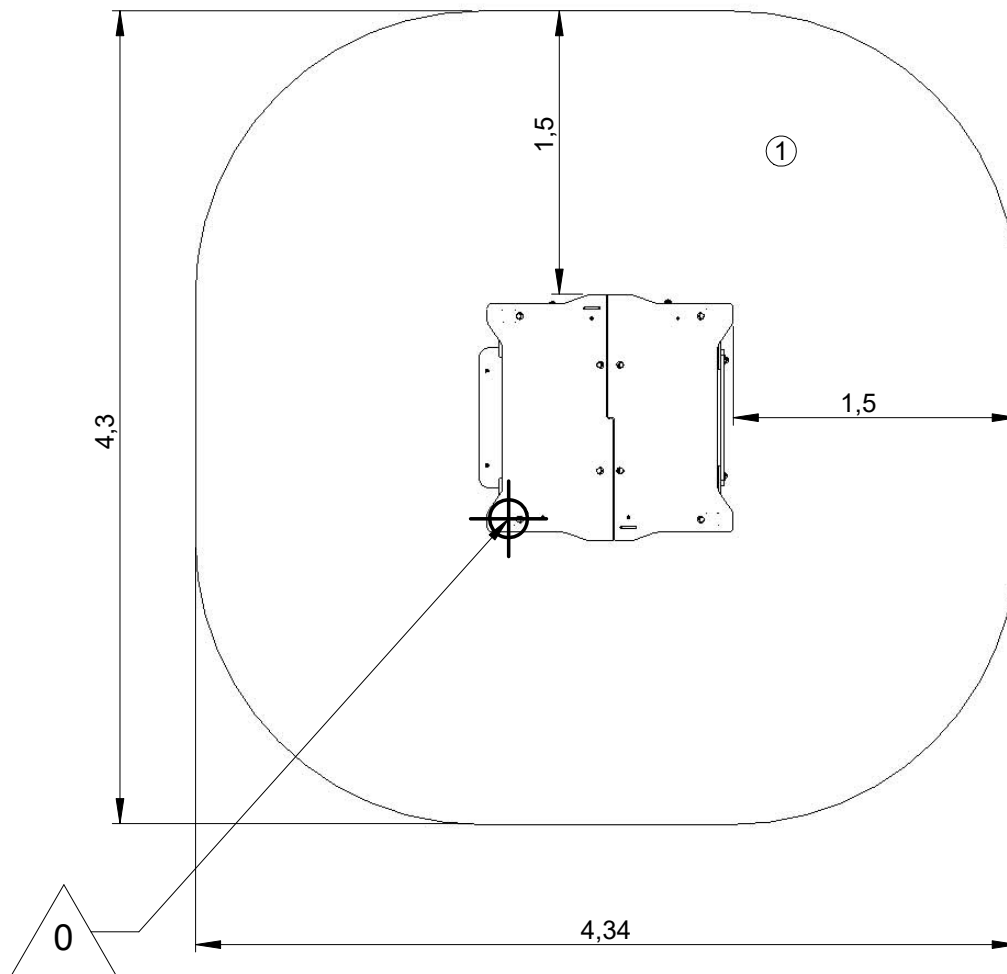

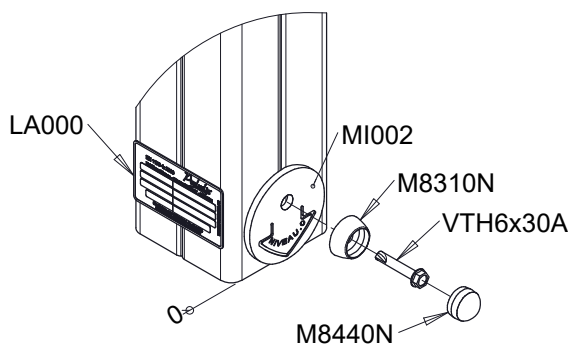
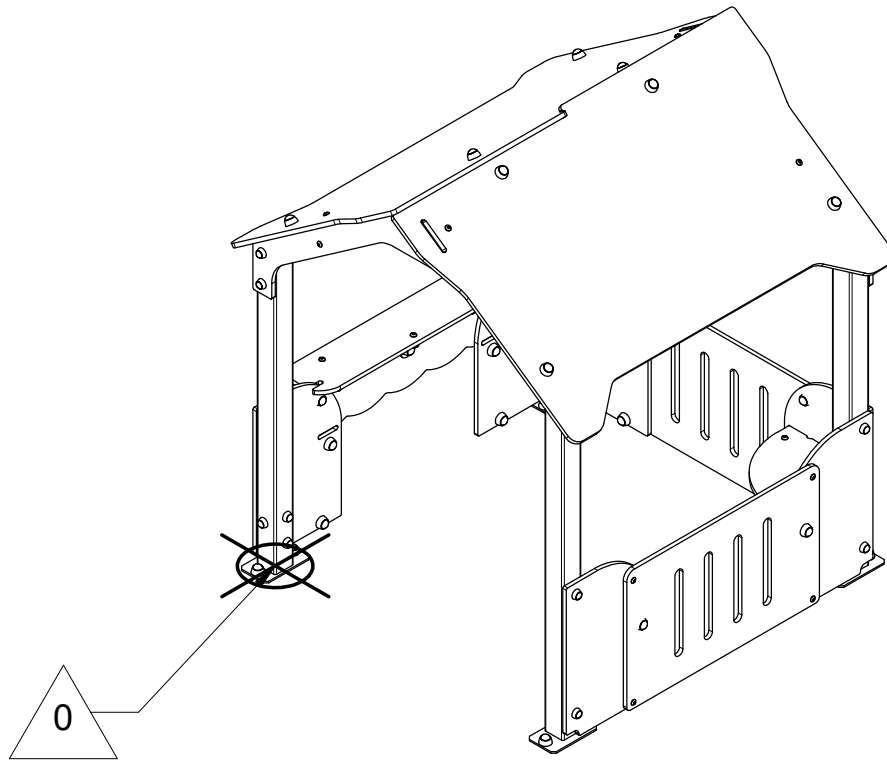

Réf	Qté
G251B	1
G254	2
G257	1
G263	1

— Zone d'impact
 Impact area
 Area de impacto
 Fallraum
 Valzone

17 m²

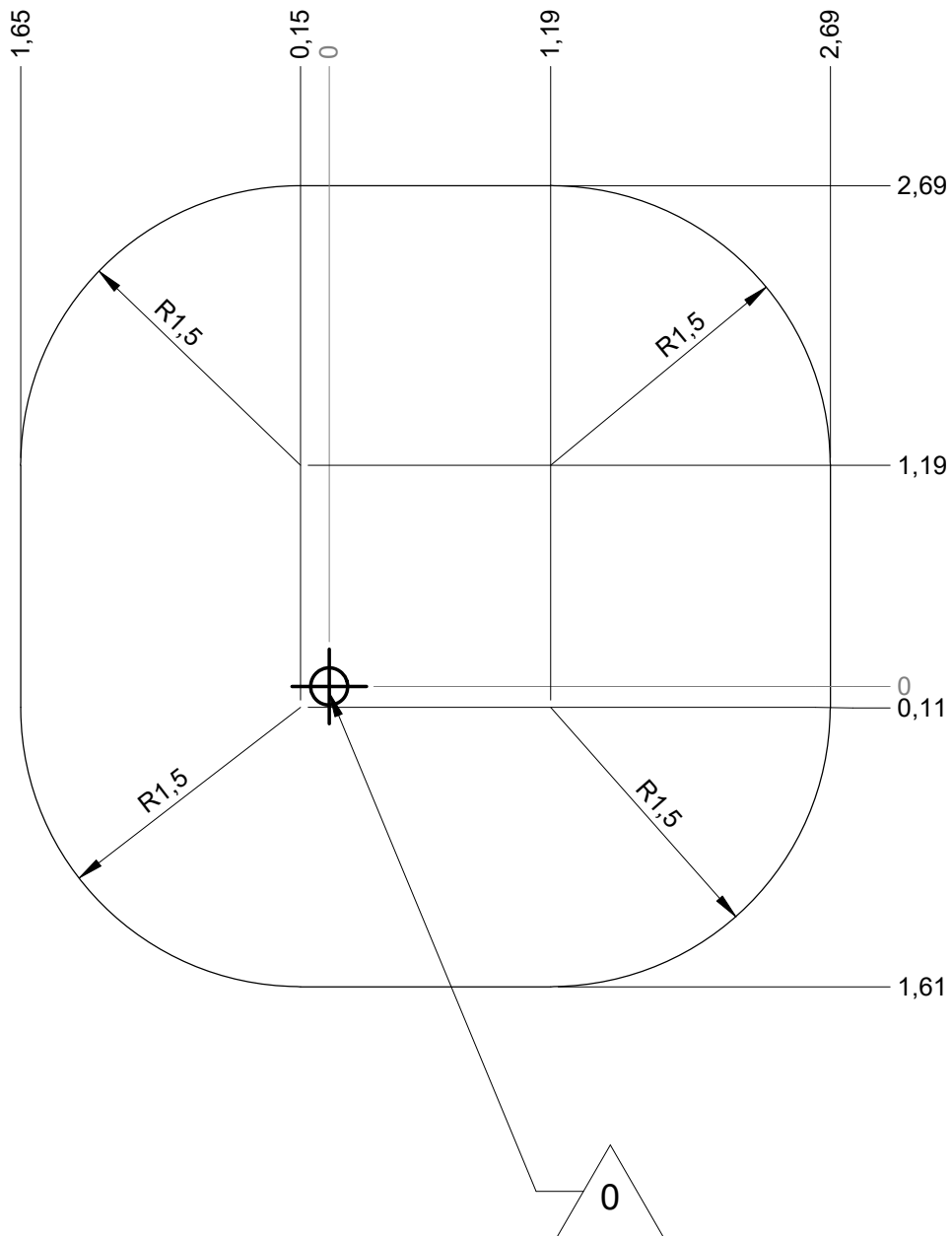

— Sol souple
Wetpour
Caucho continuo
Synthetischer Fallschutz
Gietvloer

17 m²

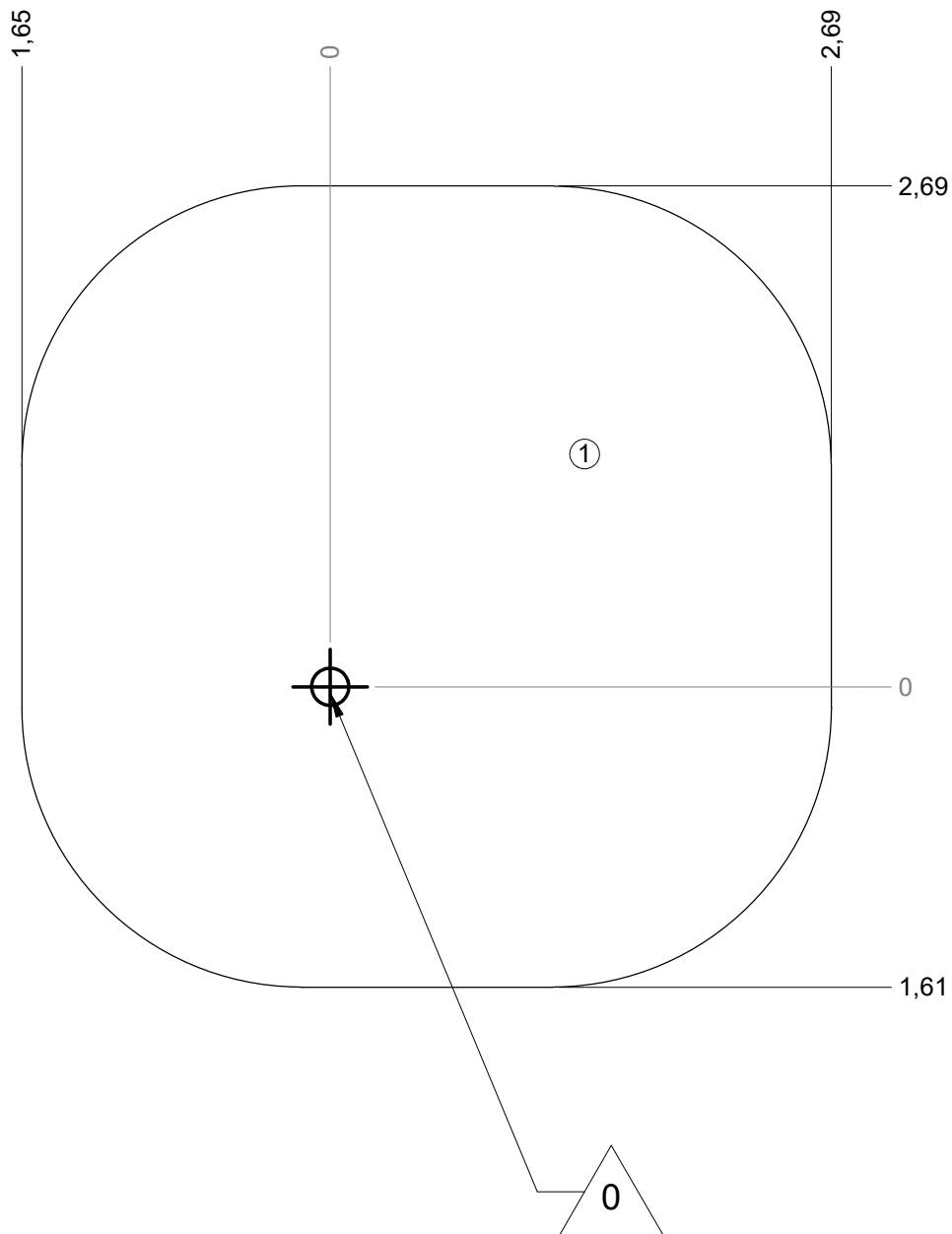

— Dalle béton
Concrete pad
Solera de hormigon
Beton Bodenplatte
Betonnen bodemplaat

18 m
19 m²

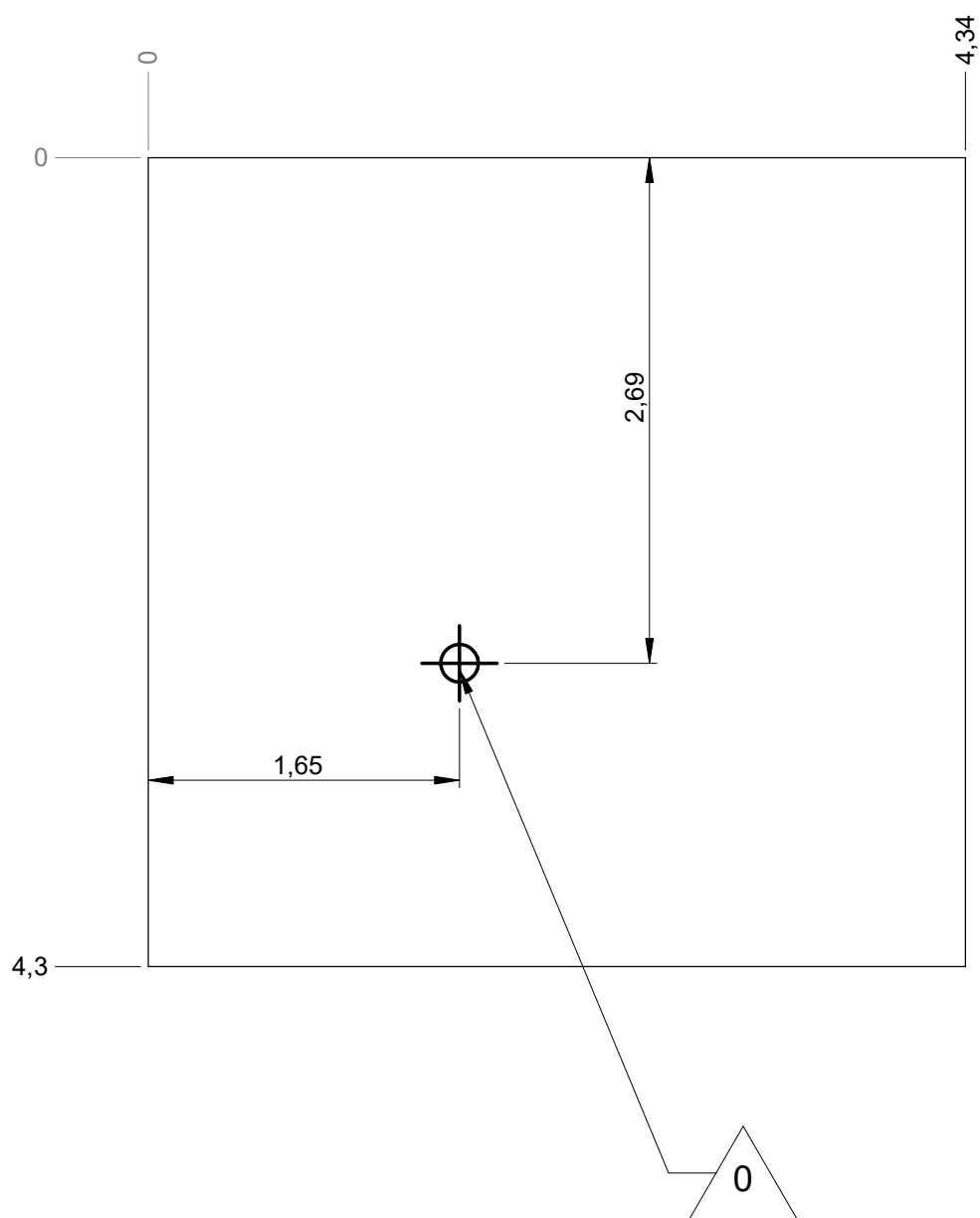

— Sol fluent
Loos partucule material 19 m
Arenero
Loses Bodenmaterial 21 m²
Los bodemateriaal

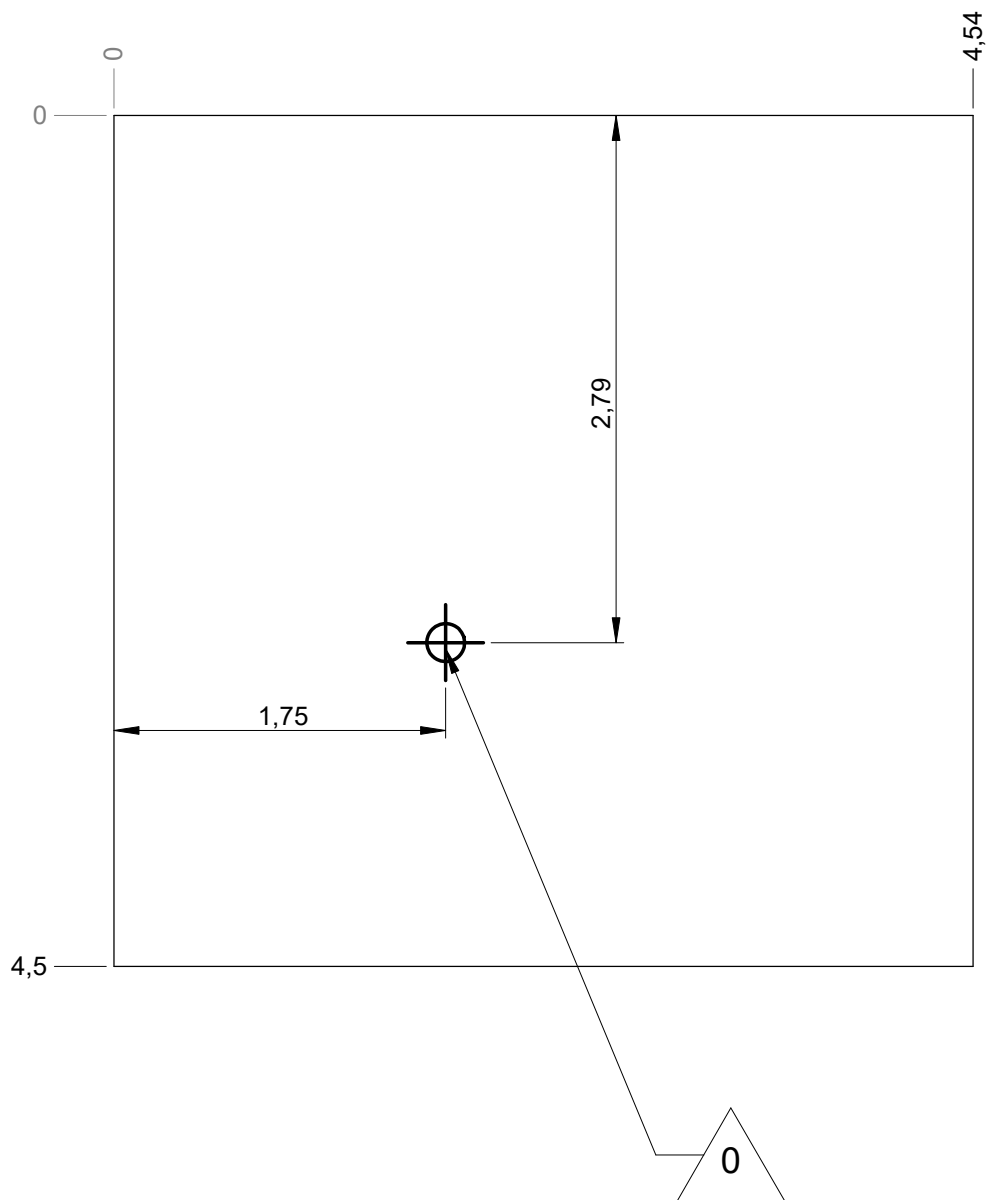

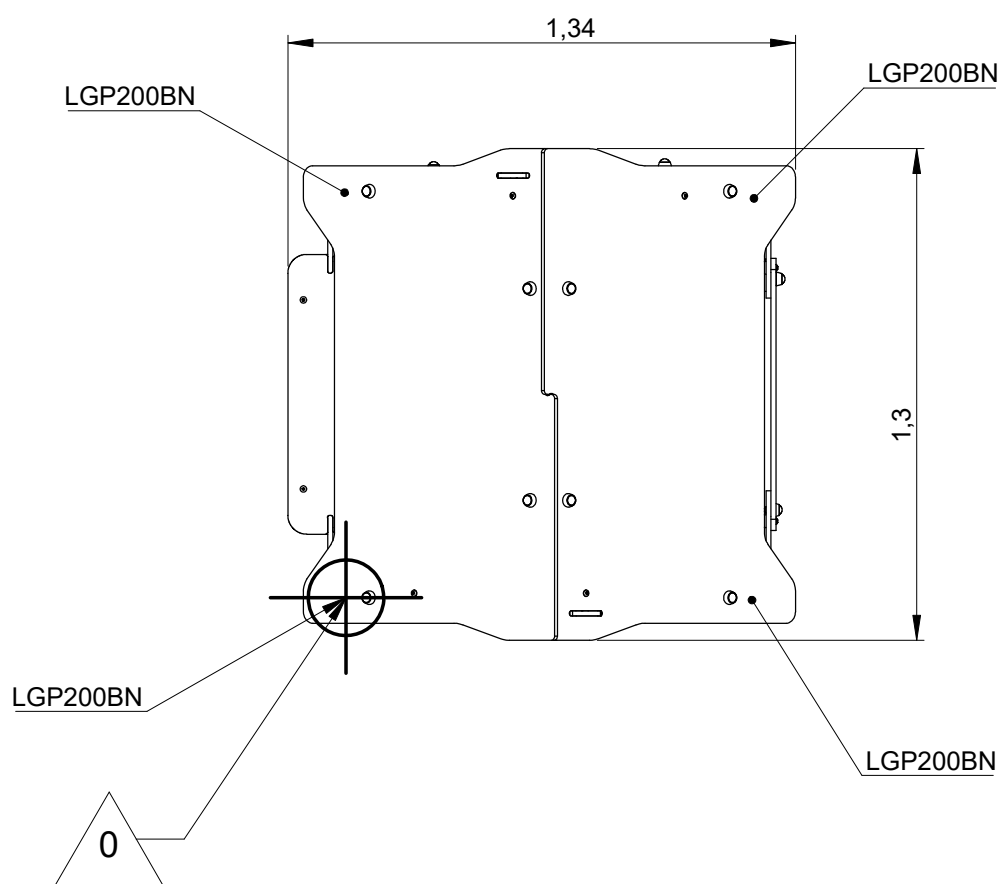

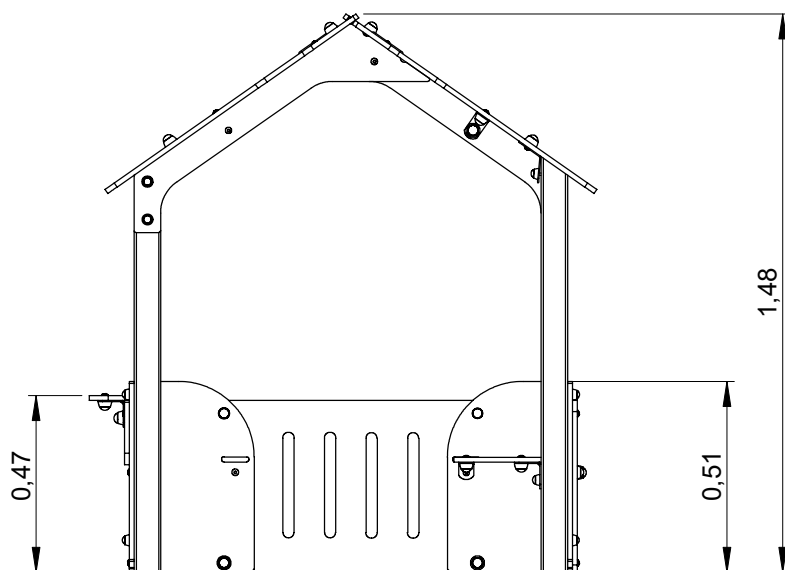

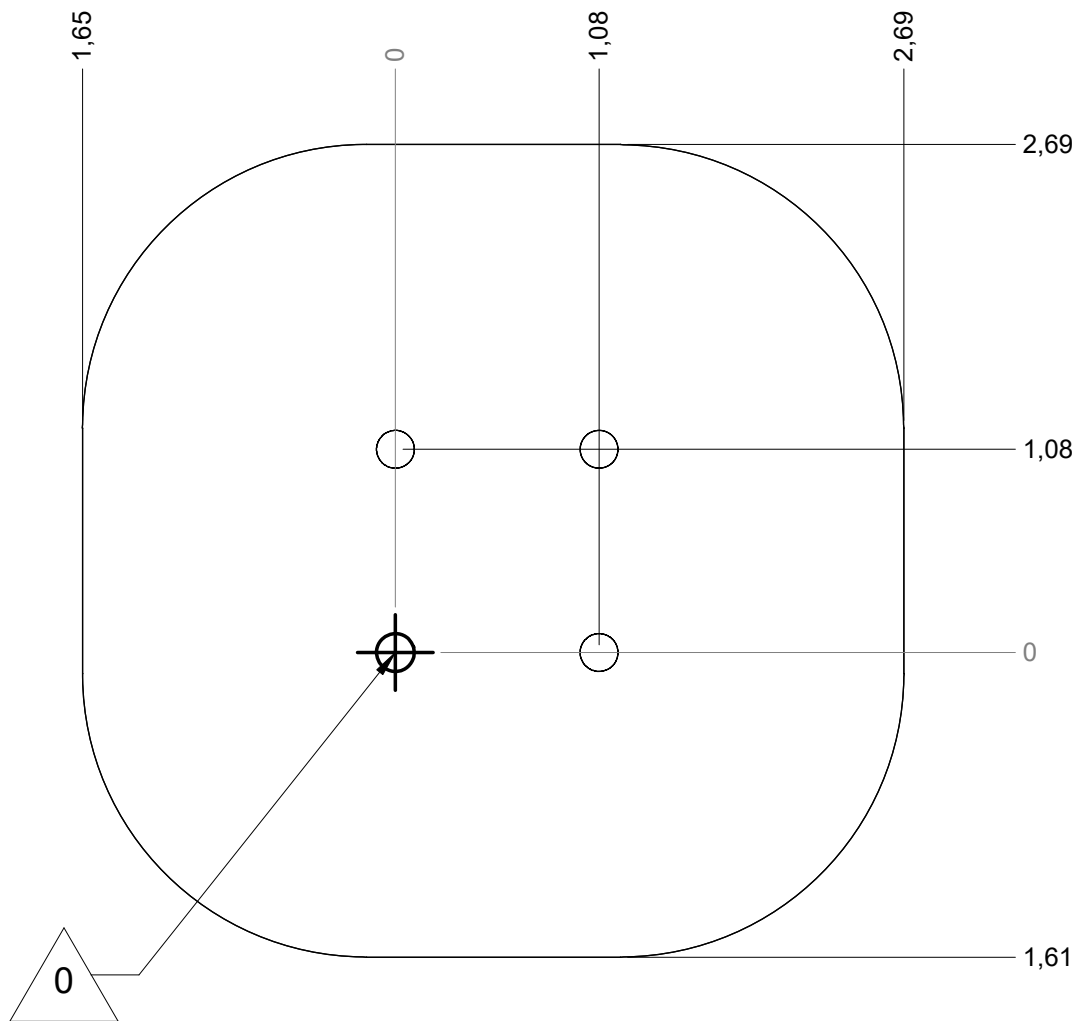

Implantation
 Footing plan
 Implantación
 Fundamentplan
 Funderingstekening



 <p>x2</p>	 <p>2H</p>	 <p>RD14M10</p>
--	---	--

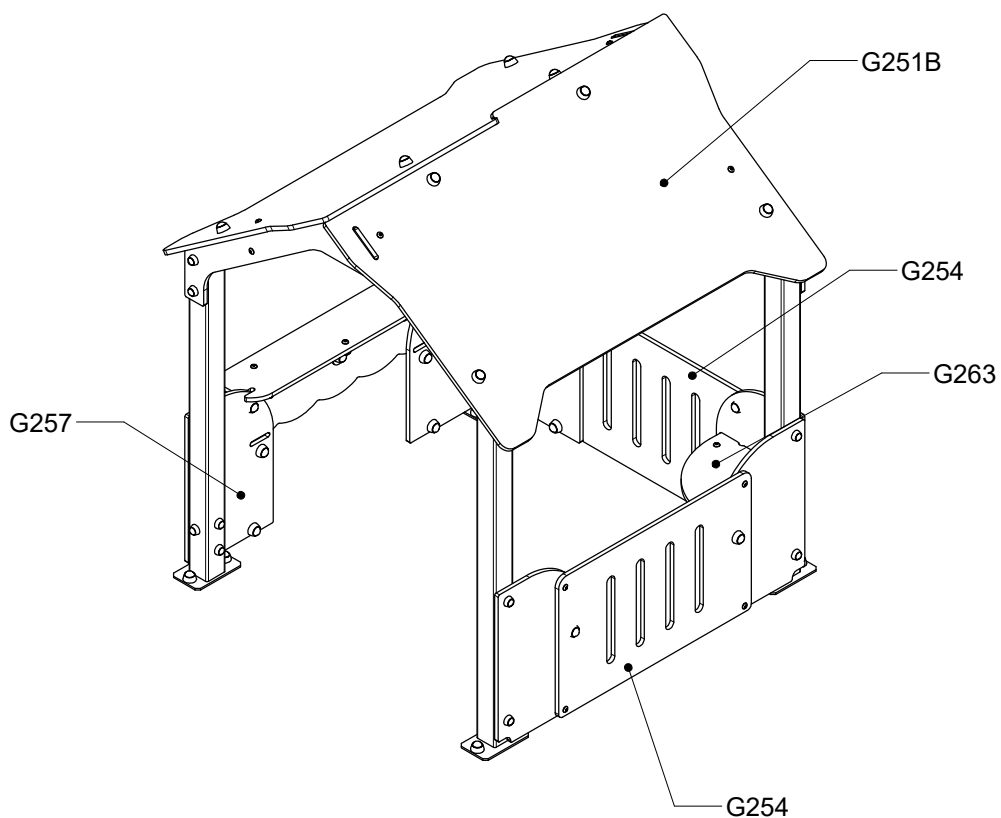

Réf	Qté
G251B	1
G254	2
G257	1
G263	1

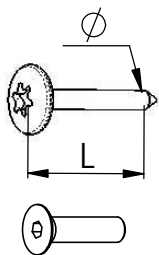

VBT 6 x 30
 \varnothing L (mm)

VFHC

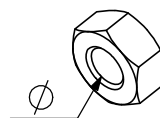

VEC M10
 \varnothing



VEF



VEB

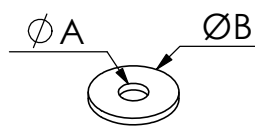

VR6x18
 $\varnothing A$ $\varnothing B$

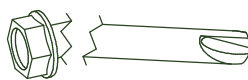

1000 - 1800 RPM
 Vitesse de rotation
 Rotation speed

< 14 N.m
 Couple de rupture
 Breakage torque

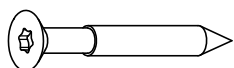

VWT

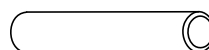

VGC

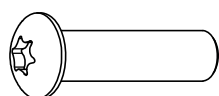

VCBHC

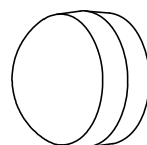

M10 440N

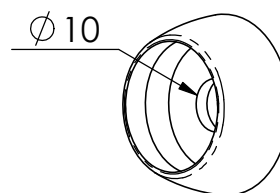

M10 310 N

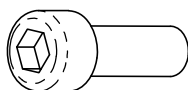

VBTR

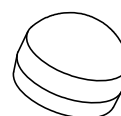

M8440N

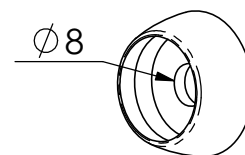

M8310N

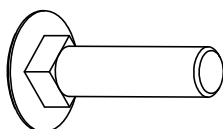

VTRCC

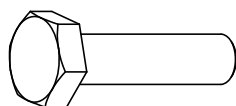

VTH

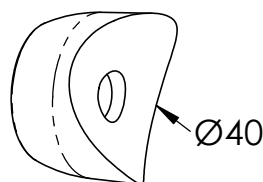

MI2503

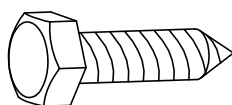

VTF

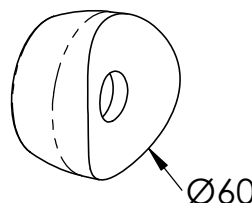

MI2701

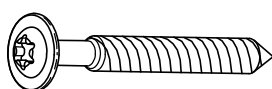

VBT

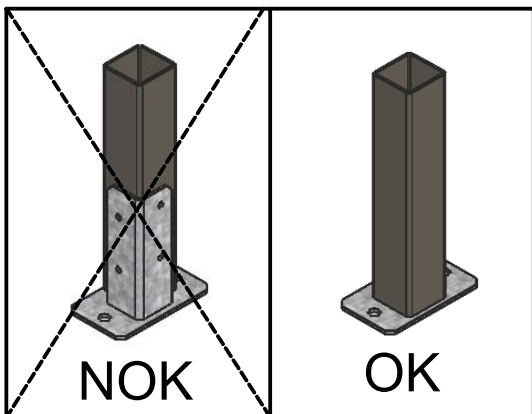
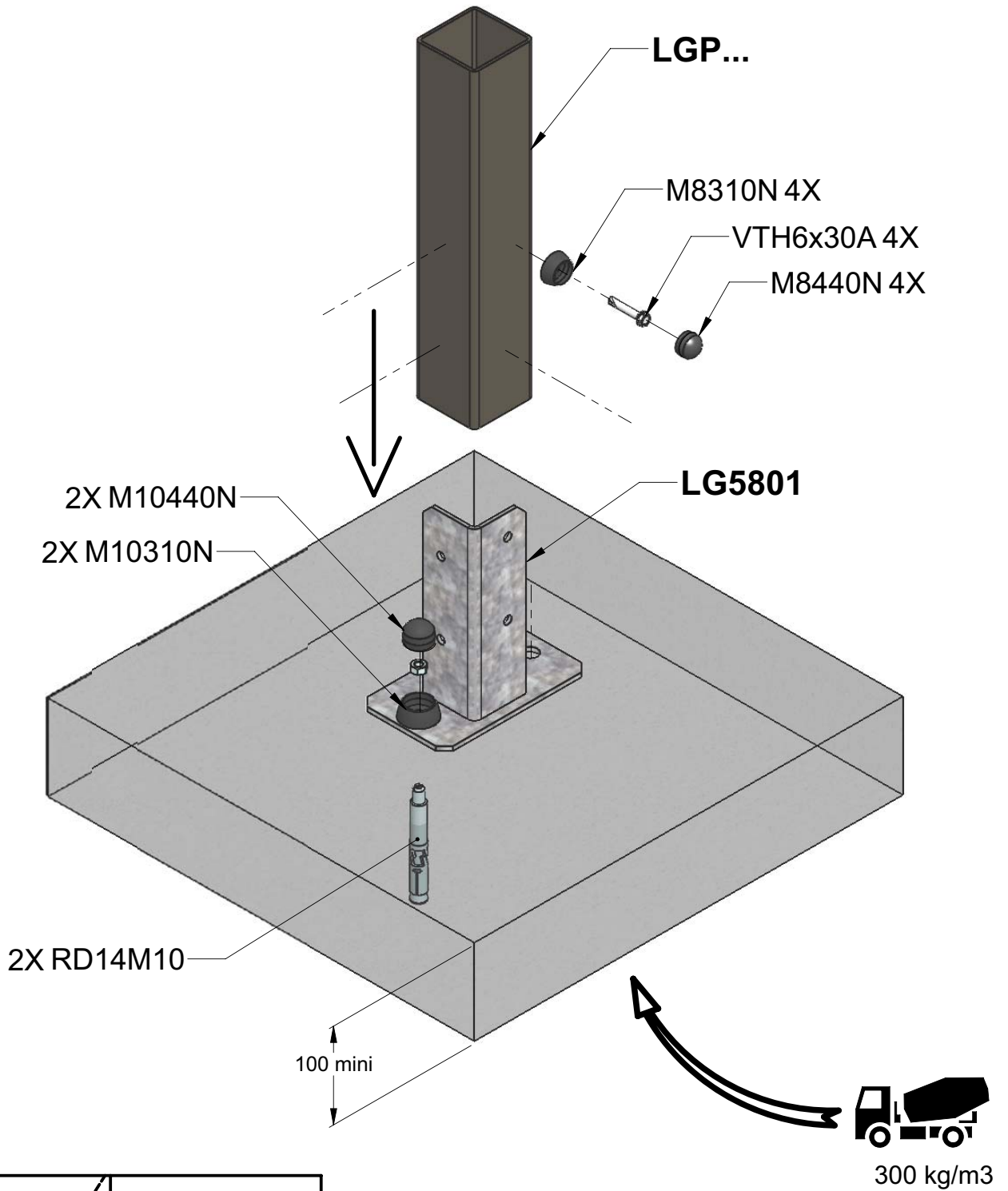

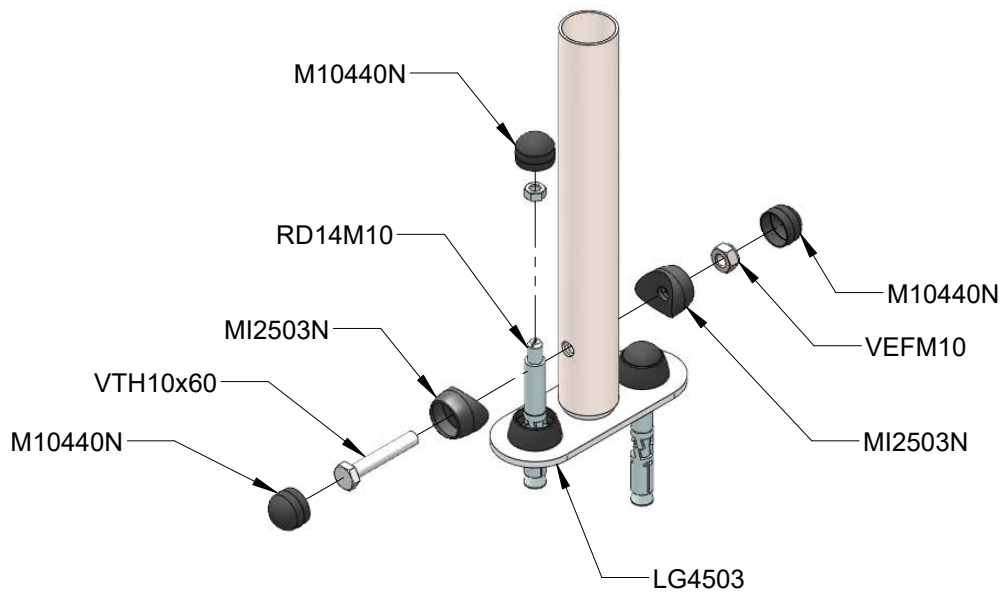

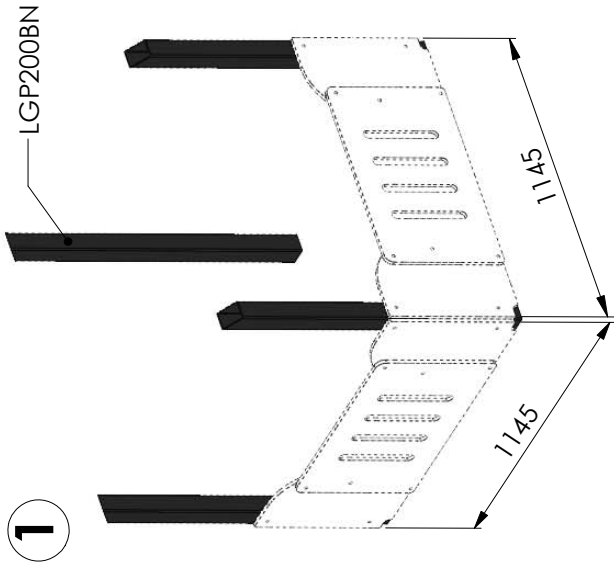

2

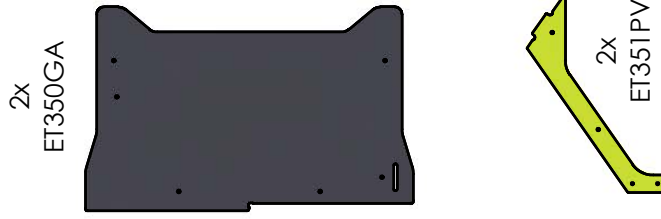
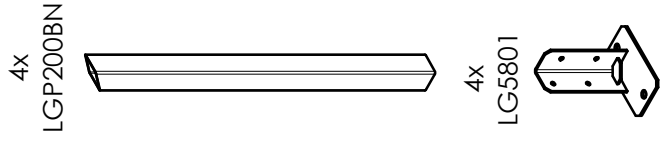

Réf	Qté
ET350GA	2
ET351PV	2
LG5801	4
LGP200BN	4
M8310N	20
M8440N	20
M10310N	24
M10440N	24
P13	4
P102	2
P120	4
RD14M10	8
VCBHCM10x30I	16
VEFM10	16
VTH6x30A	20

3

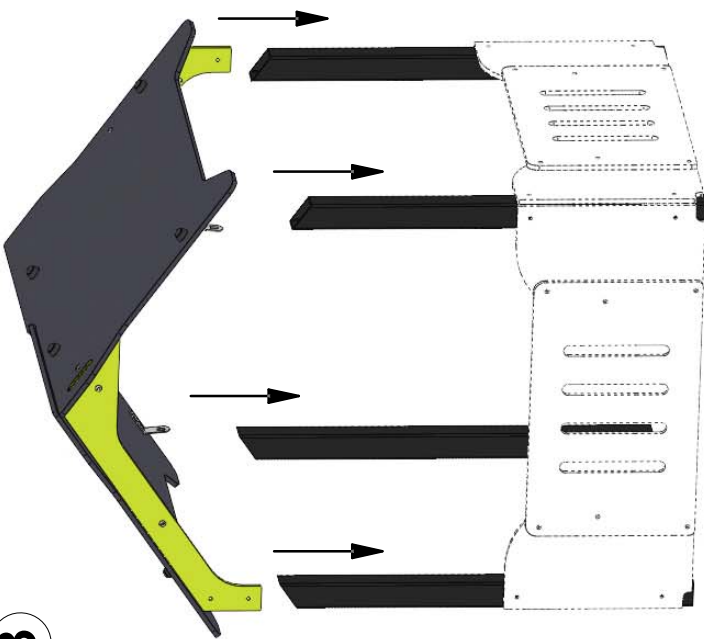

4

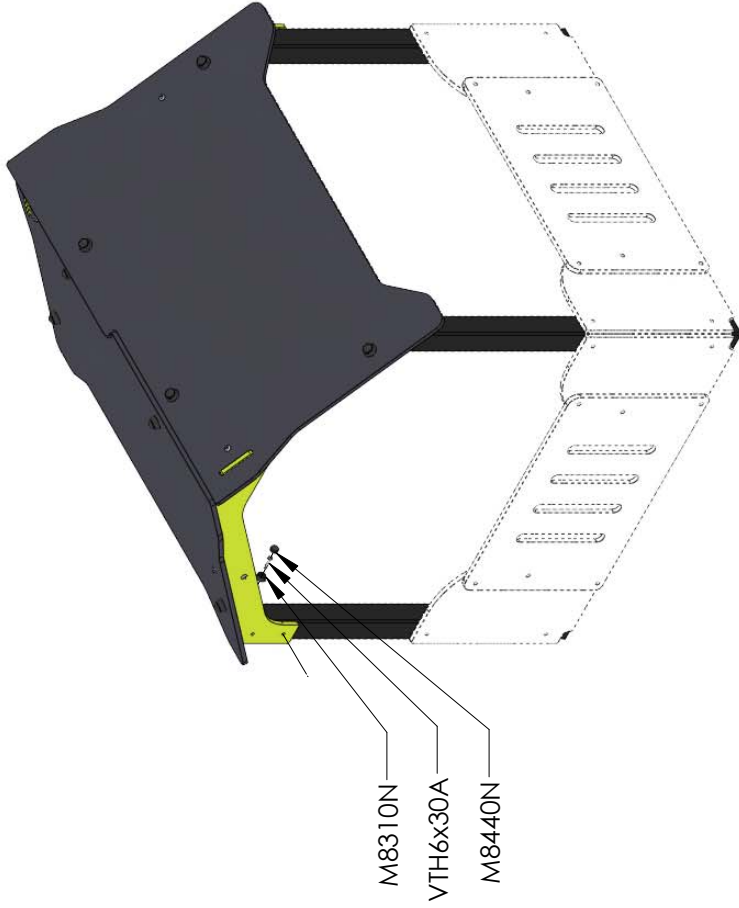

1

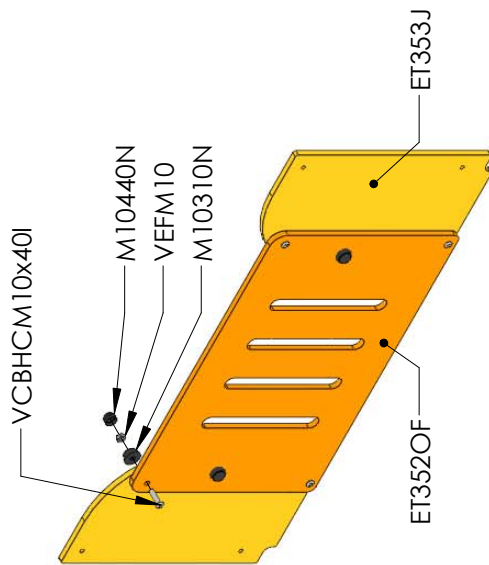

2

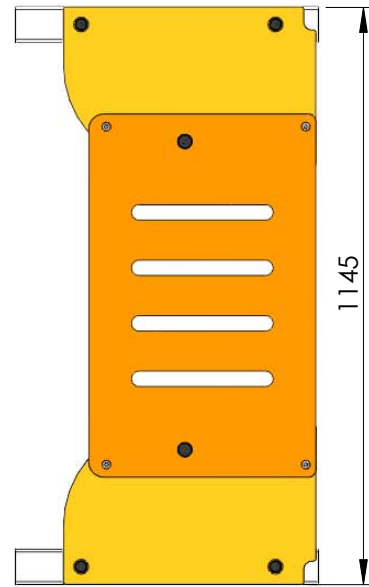
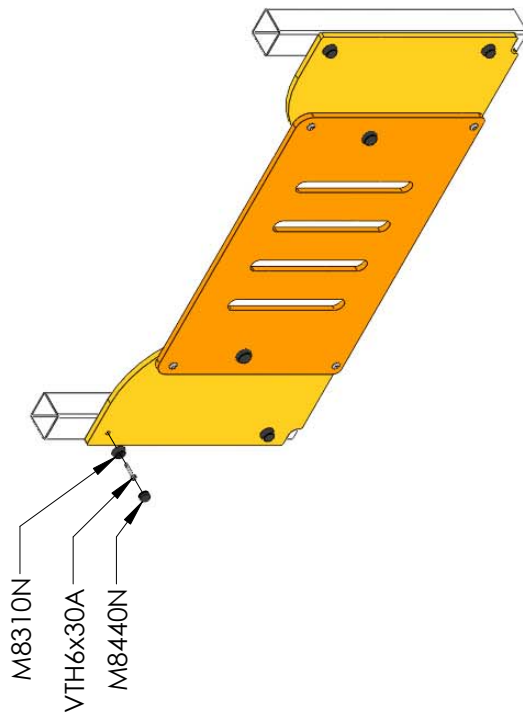

1x
ET352OF



2x
ET353J

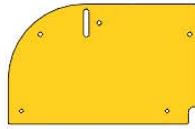

Réf	Qté
ET352OF	1
ET353J	2
M8310N	4
M8440N	4
M10310N	6
M10440N	6
VCBHCM10x40I	6
VEFM10	6
VTH6x30A	4

1

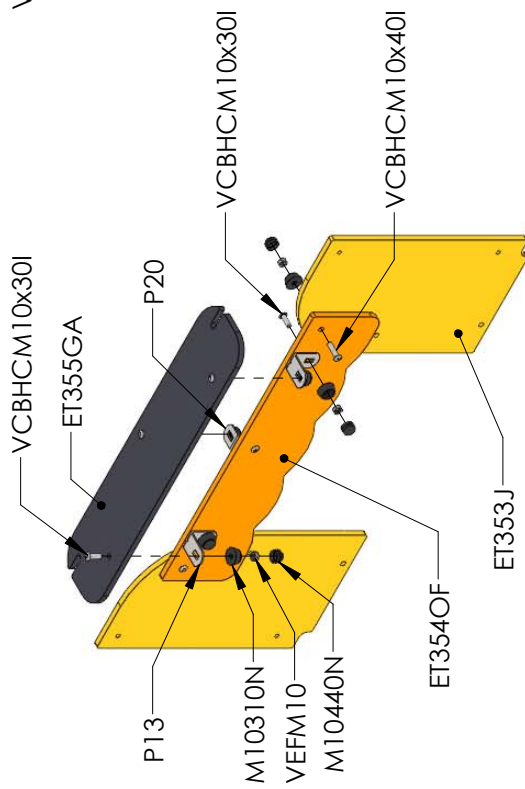

2

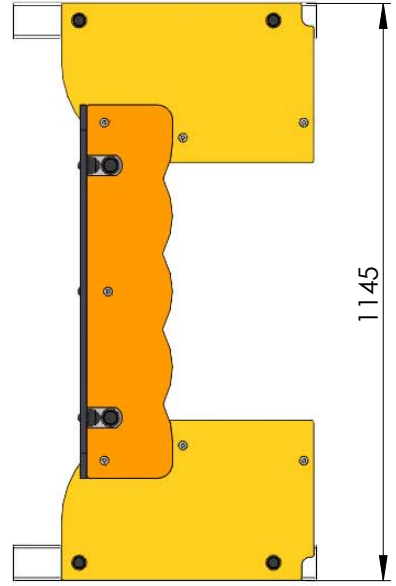
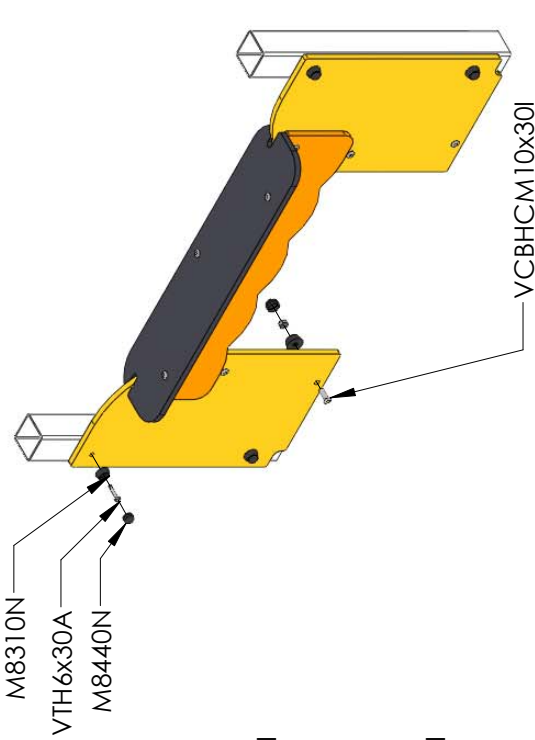

2x
ET353J

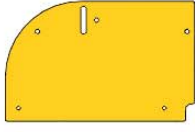

1x
ET355GA



1x
ET354OF



2x
P13



1x
P20



Réf	Qté
ET353J	2
ET354OF	1
ET355GA	1
M8310N	4
M8440N	4
M10310N	12
M10440N	12
P13	2
P20	1
VCBHCM10x30I	10
VCBHCM10x40I	2
VEFM10	12
VTH6x30A	4

1

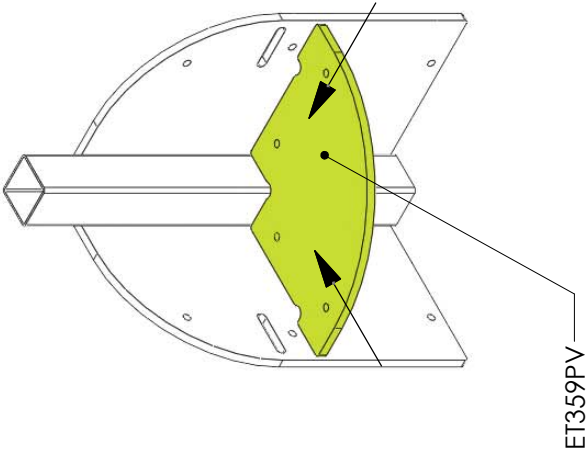

ET359PV

2

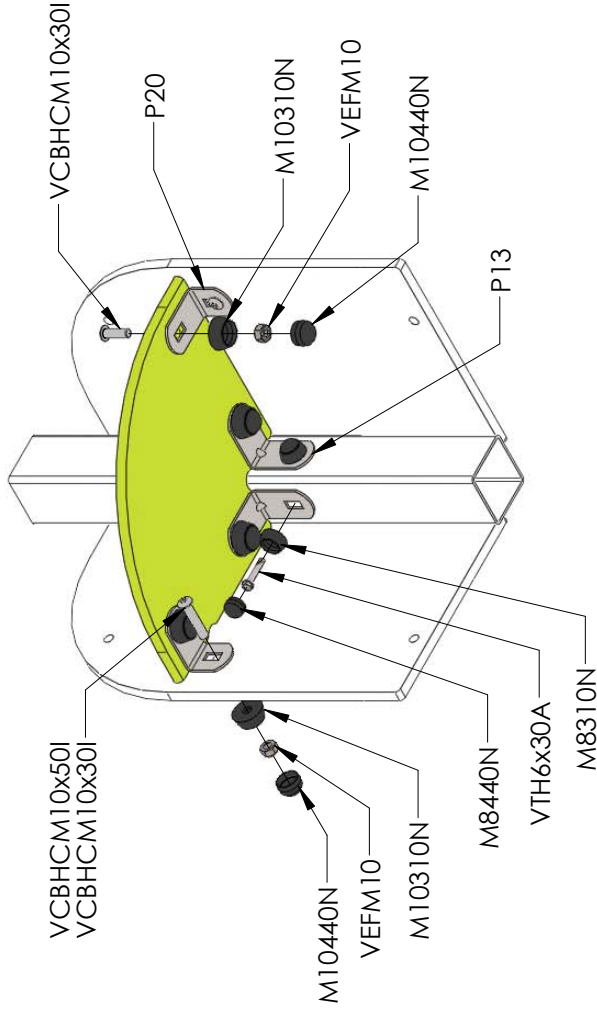

1x
ET359PV

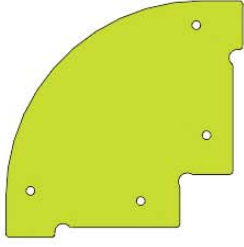

Réf	Qté
ET359PV	1
M8310N	2
M8440N	2
M10310N	6
M10440N	6
P13	2
P20	2
VCBHCM10x30I	4
VCBHCM10x50I	2
VEFM10	6
VTH6x30A	2